



COLORDMD

Installation Instructions for **S.A.M.** - CHROMA eDP

Congratulations on the purchase of a new ColorDMD display. The ColorDMD will enhance your pinball machine by introducing *color* to the dot matrix display graphics produced by the game.

Tools Required:

- 1/4" Nut Driver
- Phillips Screwdriver



Be sure to turn **OFF** the power to the pinball machine before installing the ColorDMD display.

STEP **1** Carefully remove the translite from the backbox and then lower the speaker panel to the position shown in Fig. A to gain access to the backbox.

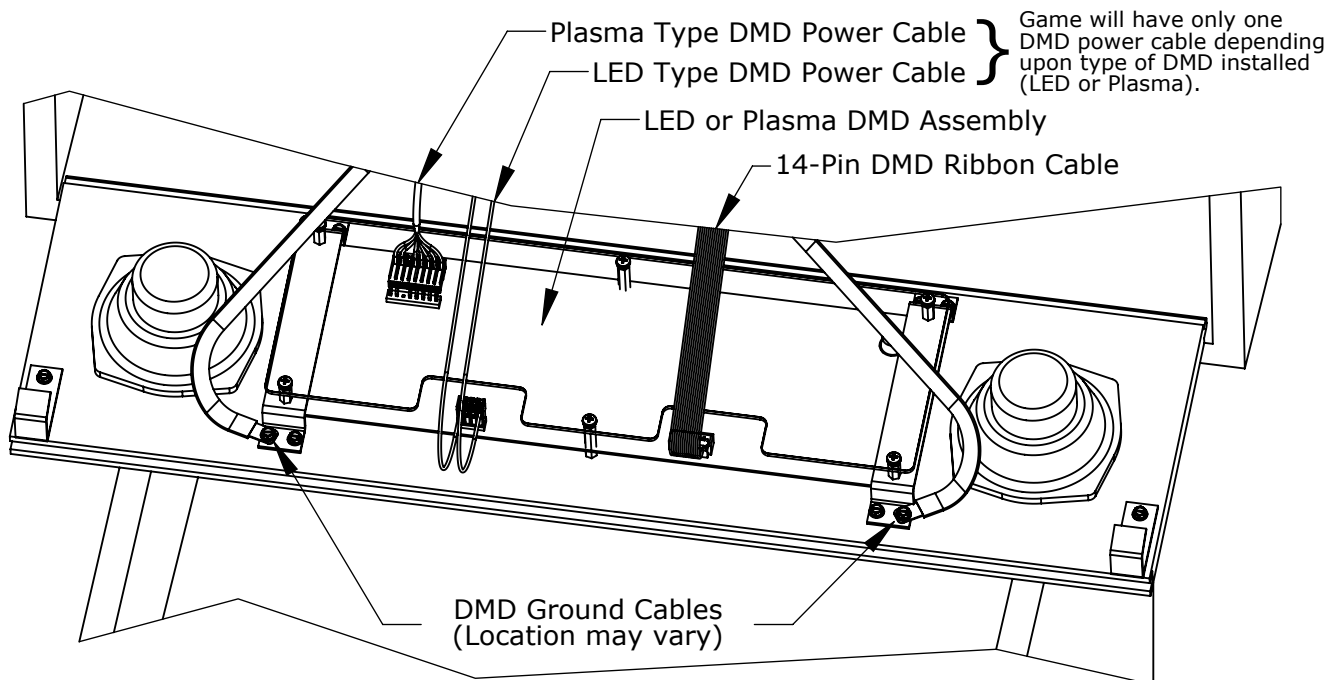

Figure A

STEP **2** Disconnect the DMD power and ribbon cables from the DMD (see Fig. A). **Completely remove the DMD Power Cable from the game by unplugging the other end in the backbox.**

STEP **3** Remove the eight DMD assembly mounting screws. **Remove the original DMD assembly from the game and store it in a safe place.**

STEP **4** If pinball machine has a transparent colored plastic film attached to the wooden speaker panel, carefully remove and store it with original DMD. If the DMD lens on the pinball machine is not clear, a clear lens (sold separately) must be installed.

STEP **5** Remove the protective film from the front side of the new ColorDMD display.

STEP **6** Position the ColorDMD face down on the speaker panel (centered in the orientation shown in Fig. B) and align the four Stern mounting holes (see Fig. C).

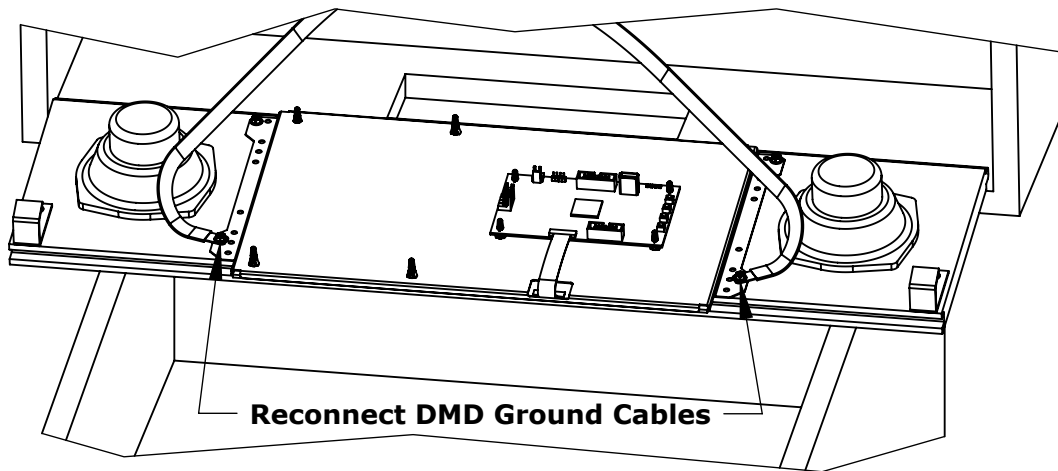

Figure B

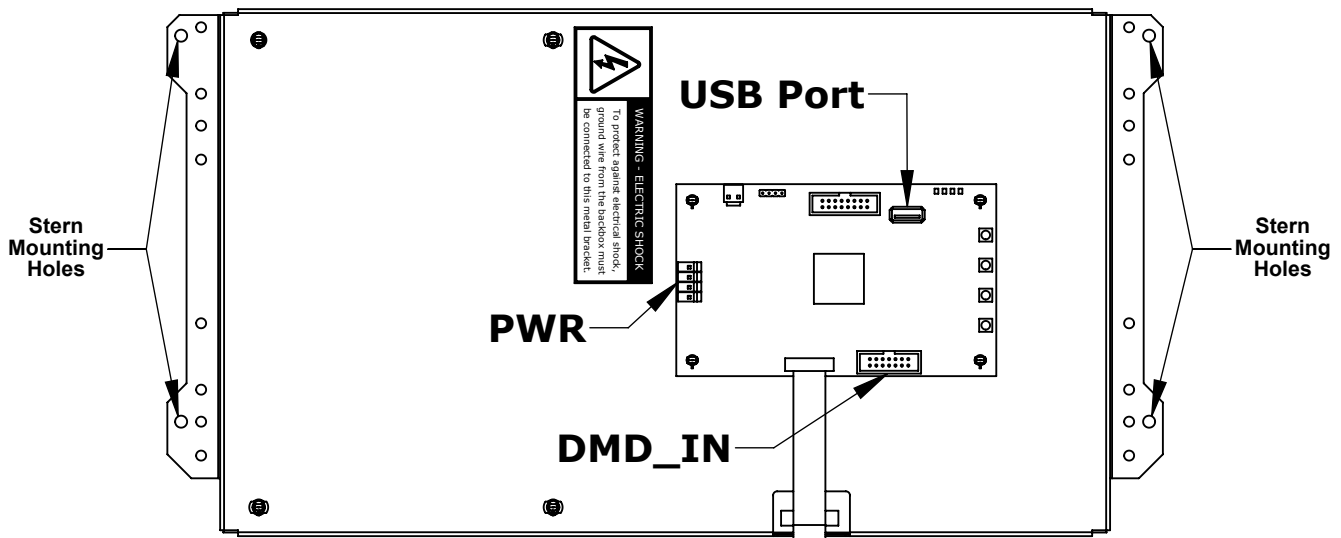

Figure C

STEP **7** Use the four included DMD mounting screws to fasten the ColorDMD display to the speaker panel. *If game has metal speaker panel, use the ColorDMD Standoff Hardware Kit sold separately to secure bracket.* **Make sure to reconnect DMD Ground Cables to the ColorDMD** (see Fig. B).



WARNING. Electric Shock Hazard - To protect against accidental electric shock, **DO NOT** operate the game without ensuring that the ColorDMD metal bracket is electrically grounded.

- STEP **8** Locate the included ColorDMD Power Cable. One end of the cable has a single connector (see Fig. D). Plug this connector into the PWR header (see Fig. C) on the ColorDMD circuit board.

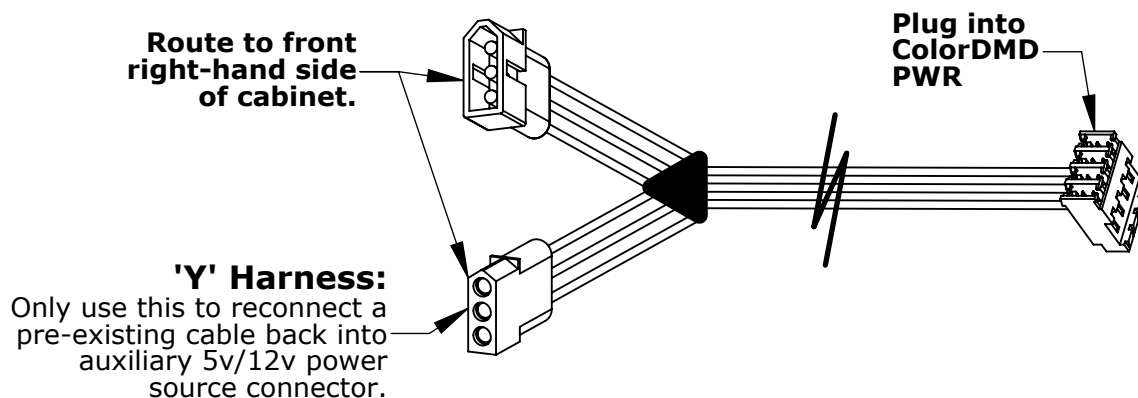

Figure D

- STEP **9** Route the other end of the new ColorDMD Power Cable down through bottom of backbox into the cabinet and over to the front right-hand side of the game. (see Fig. E).

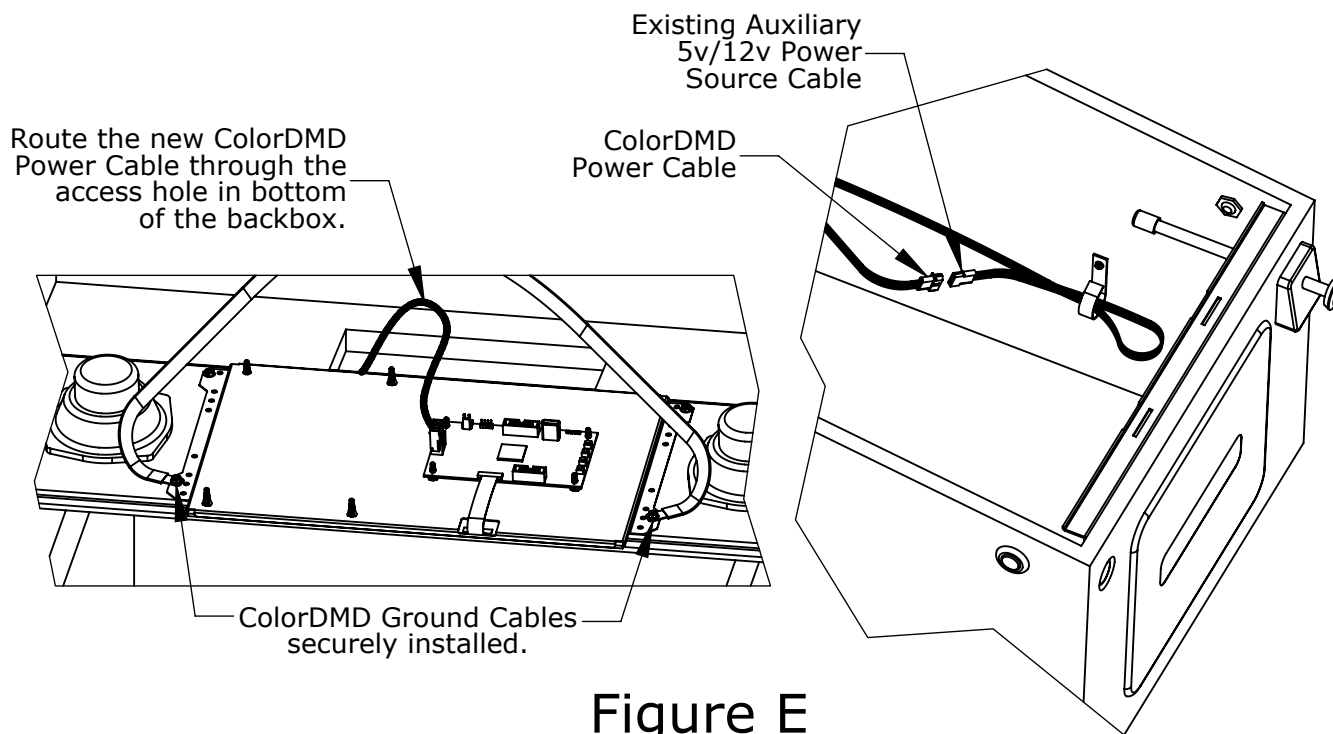

Figure E

- TIP** Route the new ColorDMD Power Cable inside the cabinet along with other existing cables for a clean install.

- STEP **10** Plug ColorDMD Power Cable into the auxiliary 5v/12v power source connector (See Fig. E). If an existing cable is currently plugged into this connector, disconnect it and plug it into the other end of the ColorDMD Power Cable 'Y' harness (See Fig. D).

- STEP **11** Plug the 14-Pin ribbon cable into DMD_IN on the ColorDMD with the **red stripe nearest the push-buttons** (see Fig. F). The other end of this cable should still be plugged into J-5 on the CPU/Sound Board with red stripe facing down.

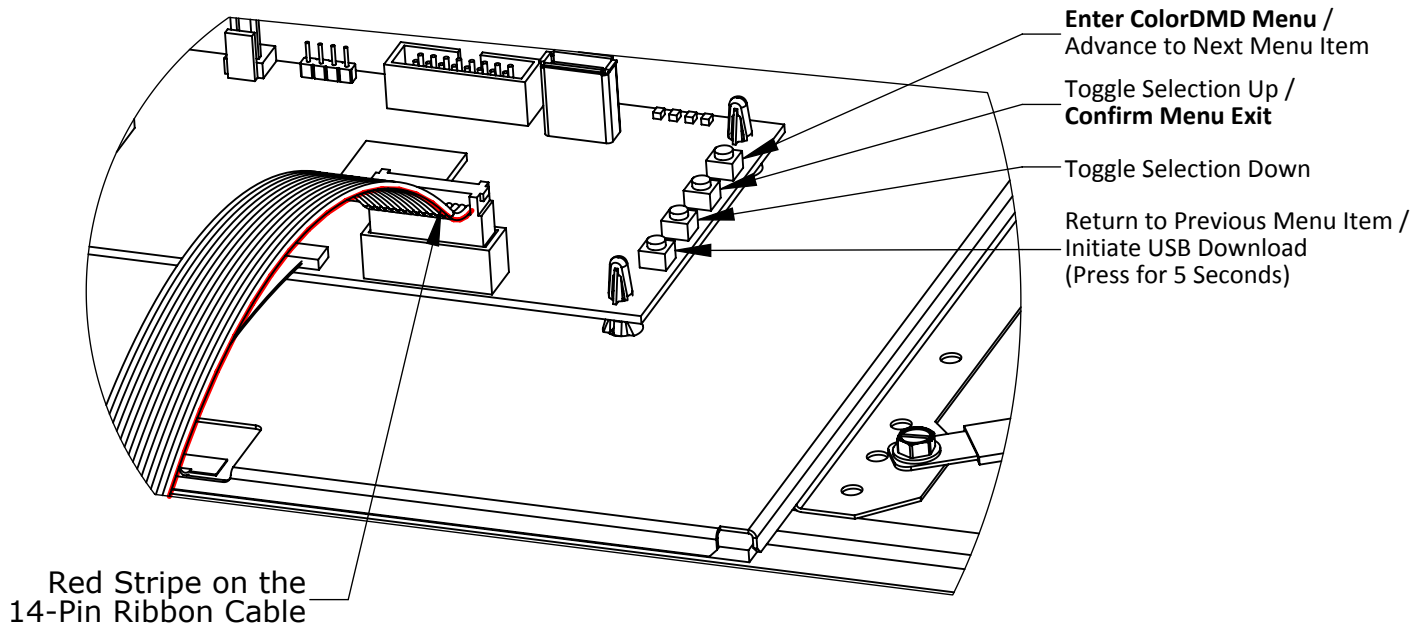

Figure F

! *Double check for proper alignment of **all** cable connections.*

- STEP **12** While ensuring no wires get pinched, raise the speaker panel and turn on the pinball machine.

- STEP **13** Locate and press the right-most *ColorDMD Menu* button (See Fig. F) to customize the display settings. Continue pressing the button to advance to the "MOUNTING" menu. Next use the *Toggle Selection Up* button to change the setting to "SAM".

- STEP **14** Press the right-most button to advance to the "EXIT AND SAVE" menu. Press the *Confirm Menu Exit* button to save settings and return to game mode. Video should appear on the new ColorDMD Display. Visit ColorDMD website to download game specific color ROM file and install using USB thumb drive. Have fun!

For additional information regarding display settings please visit our website at www.colordmd.com.